

User Manual



strongly advises to take due care in following the owner's manual. A warranty claim is invalid if damage is caused by human error, inconsistent .

TABLE OF CONTENTS

IMPORTANT SAFETY INSTRUCTIONS.....	1
Symbols In This Document.....	5
Warning Information.....	5
Caution Information.....	5
Remark Information.....	5
1. Warranty.....	6
2. Care And Maintenance.....	7
Environmental Requirements.....	9
Care And Cleaning.....	9
Maintenance.....	9
3. Overview.....	9
About	9
Monitoring Your System.....	9
Abbreviation Of Manual.....	9
List Of Goods.....	9
Install Fittings.....	9
Installation Location.....	9
4. Interface Definition.....	10
Interface Panel.....	10

LED Status Indicators.....	10
CAN/RS485 Interface Definition.....	10
Schematic Diagram Of Connection With Inverter -Simple Connection.....	10
Schematic Diagram Of Connection With Inverter - Recommended Connection.....	10
product Power Cable Connection.....	10
product On And Off.....	10
product Communication Interface.....	10
Connect With Inverter.....	10
Inverter Support List.....	10
Operating.....	10
Trouble Shooting.....	10
Technical Support.....	10
5. How To Deal With An Emergency.....	10
6. When The Product Is Turn Off And Not In Use.....	12
7. System Message.....	13
Quality Assurance.....	14

IMPORTANT SAFETY INSTRUCTIONS

Save These Important Safety Instructions

Important: This product should not be used for any purpose other than that described in this user manual.

Power Porter installation and service require knowledge of high voltage electricity and should only be performed by Certified Installers. not responsible for injuries or property damage caused by unqualified personnel trying to repair or failing to follow these instructions correctly. These warnings and cautions must be followed when using .

Symbols in This Document

This manual uses the following symbols to highlight important information:



WARNING:Indicates a hazardous situation which . If not avoided, could result in death or serious injury.



CAUTION: Indicates that damage or injury may occur. If not avoided, it may cause minor injury or property damage.



NOTE: Indicates a risk of possible damage to the product.



WARNING INFORMATION:

- Installation must be carried out only by Certified Installers who have been trained.
- In the power regulation circuit, due to the high voltage, there is a high possibility of electric shock or severe burns.
- High voltage on AC and DC cables. There is a risk of death from electric shock or serious injury.
- There are potential dangers such as death or serious injury caused by fire, high pressure or explosion caused by this product, if you have not read or do not fully understand the appropriate preventive measures.
- Do not place flammable and explosive materials near the product.
- Do not place any objects on the product during operation.
- All the work of PV, power supply regulation and battery system must be completed by qualified personnel.
- Electrical installation must comply with local and national electrical safety standards.
- Wear rubber gloves and protective clothing (protective

glasses and boots) when working on high-voltage/high-current systems (such as PCS and battery systems).

- Please do not remove the product cover, there is a risk of electric shock, and there are no user-usable parts inside. Request service from qualified and approved service technicians. Do not touch uninsulated wires.
- In the event of a failure, the system cannot be restarted. Product repairs must be performed by qualified personnel or authorized support center personnel.



CAUTION INFORMATION:

- The accessories are contained in this box, the total weight is too large. Because the product is too heavy, it may cause serious injury. Therefore, special care must be taken when handling. Make sure that at least two people deliver and move the package.
- Do not use damaged, cracked or frayed cables and connectors. Protect the cable from physical or mechanical damage, such as the cable being twisted, clamped, closed on the door, or trampled by someone. Check the cable of your product regularly. If its appearance shows damage or deterioration, stop using this product and contact a qualified person to replace the cable.

- Make sure that the product you are connecting is grounded to prevent possible electric shock. Do not attempt to achieve grounding by connecting the product to telephone lines, lightning rods, or gas pipes.
- If is defective, cracked, broken or otherwise damaged or inoperable, please do not use that again.
- This product should not come into contact with water (drip or splash), and should not place objects filled with liquids such as vases on this product.
- To prevent the risk of fire or electric shock, do not expose this product to rain or moisture.
- Keep out of reach of children or animals.
- Products must be handled in accordance with local regulations.
- The electrical installation of this device must be carried out by an electrician or technician with PCS qualification.
- To avoid radio interference, all accessories (such as smart meters) connected to the product must be suitable for residential, commercial and light industrial areas.
- Connect the DC + and DC- cables to the correct DC + and DC- terminals on the product.
- Do not step on the product or product packaging. The

product may be damaged.

- Do not discard the battery in a fire. The battery may explode.
- Do not open or damage the battery. The electrolyte released may be toxic and harmful to the skin and eyes.
- Batteries are in danger of electric shock and large current discharge during short circuit. Pay attention to the following when installing the battery.

a) Disassemble watches, rings or other metal objects.

b) Use tools with insulated handles.

c) Wear insulated gloves and boots.

d) Do not place tools or metal parts on top of the battery.



PV PANEL CONNECTION REMARK INFORMATION:

- Before connecting, please make sure that the open circuit voltage of the photovoltaic array is within the acceptable range of the inverter to which the product is adapted, otherwise the product may be damaged.
- Never use any solvents, abrasives or corrosive substances to clean this product.
- Do not store or place any objects on the product. It may cause serious defects or malfunctions.

- Before connecting the product to the inverter terminal, make sure that the product is turned off, the inverter is turned off and the mains and PV channels are disconnected.
- The wiring terminal of the product is only allowed to be connected to the adaptable inverter. Do not connect this product directly to the AC power supply or generator. Connecting the product to other external devices may cause serious damage to the device.
- The product transportation process should be as stable as possible, to avoid the product in the environment of severe vibration.
- The supply of products should be performed or supervised by personnel with battery knowledge and necessary precautions.

1. Warranty

For specific warranty details, see the attached page of this document .

For more information, please refer to the Warranty in your region .

2. Care And Maintenance

Environmental Requirements

charge and discharge within the operating

temperature range specified below. In extreme temperature ranges, may limit the power of the battery when charging or discharging to improve battery life.



Remarks: needs to keep the ambient temperature within the range of 0°C ~ 45°C during startup.

Battery Operating Temperature	Charging: 0°C to 45°C Discharging: -20°C to 45°C
Battery Storage Temperature	- 10°C to 45°C

Care And Cleaning

If installed outdoors, please ensure that there are no leaves and other debris around to maintain optimal airflow.



CAUTION: Do not lean, stack, or hang anything around and from wires to it.



CAUTION: When cleaning the product, use a soft, lint-free cloth.

It is recommended to use dry and soft cloth, if necessary, only moisten with mild water.



CAUTION: Do not use cleaning solvents to clean product ,

or expose product to flammable or harsh chemicals or vapors.

Maintenance

The only maintenance required by the user for the product is to keep the product free of debris .

3. Overview

About product

This product is mainly combined with inverter, photovoltaic (PV) and related accessories to build residential energy storage system. The system is used to store the power generated by PV to the connected battery and convert the direct current (DC) generated by the connected battery into alternating current (AC) and provide it to the home grid.

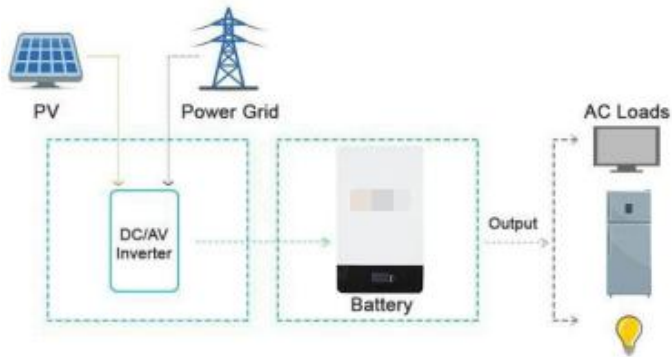

(Note: The actual Residential ESS may also include electrical equipment such as distribution boxes and metering meters)

product is a lithium-ion battery that can store electrical energy and outputs DC current. product only maintains electrical connection with the inverter. The electrical energy generated by the PV is converted by the inverter Dc to DC and stored in the connected product. When product is needed, electrical energy is converted by the inverter DC to AC and transmitted to the home grid to provide power for household appliances.

The main function of the home energy storage system depends on the inverter. product is a device that stores electrical energy.

Functions of home ESS:

- Self-production and sales of electrical energy
Use solar power and product to reduce the dependence on the grid and store electricity during the day for night use.
- Backup power
When the power grid is out of power, it can be seamlessly switched to product as a backup power source to protect your home from power outages.
- Sell electrical energy
The electrical energy generated by the photovoltaic array can be stored in a connected product or sold to an energy supply company.
- Off-grid power supply
The system can be connected to diesel generators to ensure uninterrupted power supply in areas without city power (such as islands and remote mountain areas).

(Note: The scheduling management of electrical energy in the system depends on the inverter. product is comm itted to being compatible with a variety of inverters. The inverter you use does not necessarily contain all the above functions)

Monitoring Your System

Using the app, you can monitor system operation from your mobile device, including the following:

- Real-time power usage
- Energy consumption history
- Relative amounts of energy used from solar, grid, and product storage

Abbreviation of manual

Abbreviation	Full Name	Explanation
ESS	Energy Storage System	System for storing energy to battery and using energy stored in battery.
PV	Photovoltaic	Photovoltaic system that converts solar energy into direct current.
SOC	State of charge	Current battery level
BMS	Battery Management System	Lithium battery management system
DC	Direct Current	-
AC	Alternating Current	-

LCD Screen Instruction

Pack V	Pack Voltage
IM(0.00A)	
PCB_T	Printed Circuit Board Temperature
ENV_T	Environment Temperature

SOC	Status of Capacity
FCC	Full Charge Current
RM	Remains
CC	Charging Cycle
SCP	Short-Circuit Protection
O/UTP	Over/Under-Temperature Protection
OCP	Over Current Protection
UVP	Under-Voltage Protection
OVP	Over-Voltage Protection
OT	Over-Temperature
OTP	Over-Temperature Protection
OV	Over-Voltage

UV	Under-Voltage
OC	Over-Current

Product Label And Warning Label

Dawnice

MODEL NAME: Dawnice 10
 CAPACITY: 202AH
 NOMINAL VOLTAGE: 51.2V
 NOMINAL ENERGY: 10.34kWH
 short Circuit Current: 3.675kA
 S/N:



Power Cables x 2



Mounting Brackets x 1



User Manual x 1

No.	Project	Explanation
1	PS- GC5KWH	Energy storage battery.
2	Power Cables x 2	Connect with the inverter to carry out power transmission with it .

3	Mounting Brackets×1	To fix the PS- GC5KWH to the wall
4	User Manual×1	-

Install Fittings

product Installation Location



Mounting Brackets x 1



The product installation must meet the requirements described below.

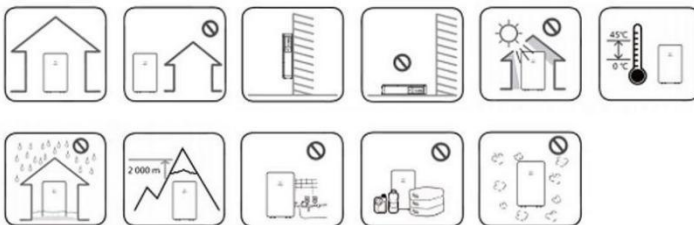

- This product is recommended for indoor use. If the product is installed outdoors, it must be ensured that the product is not exposed to direct sunlight, wetted by liquid, or blown by strong wind under any circumstances.
- It is recommended to install this product in the place where photovoltaic cables, mains cables and capacity are arranged.
- This product is only suitable for vertical wall-to-wall installation. Do not lay this product on the ground.
- The mounting surface must be able to bear this weight.

Product (~53kg).

- The suitable operating temperature of the product is 0°C ~ 45°C.
- Do not install this product in direct sunlight.
- Install the product in a clean and cool room.
- This product must not be installed or used at an altitude of more than 2000 meters.
- Do not install this product in the place where frequent flooding occurs.
- Do not install this product in a bathroom with high humidity.
- This product generates low noise at a specific time, and the installation location needs to consider sound insulation.
- The noise level may vary depending on the installation location.

- Do not install the product where there is vibration.
- Do not install this product in the place with ammonia, corrosive steam, acid or salt.
- Installed out of the reach of children and pets.
- Do not install this product in places and environments where large amounts of dust are likely to accumulate.

4. Interface Definition

Interface Panel

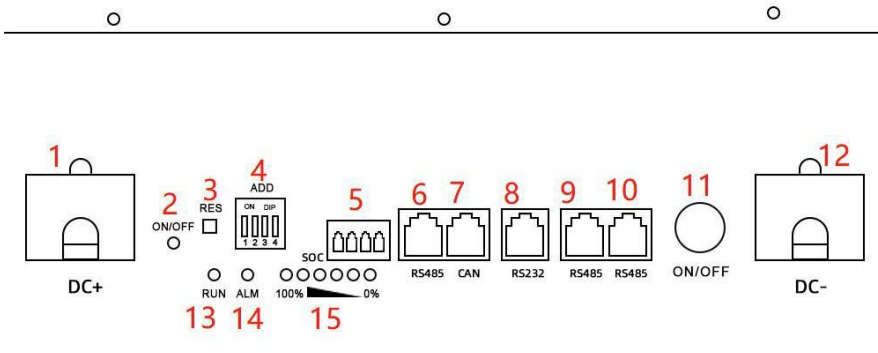

Port Interface

Pin	Definition	Description
1	DC +	Positive Terminal
2	ON/OFF	Battery is on/off
3	RES	Reset Button

4	ADD	Device address dial switch
5	Dry Contact	Dry Contact
6	RS485	Port communication with inverter
7	CAN	Port communication with inverter
8	RS432	Port communication with inverter
9,10	RS485	Communication between batteries
11	ON/OFF	Power Button
12	DC-	Negative Terminal
13	RUN	Battery is working well
14	ALM	Battery Fault
15	SOC-LED	Battery Charge Status

LED Status Indicators

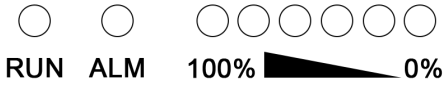

System status	Running status	Run	ALM	SOC				Remarks
		●	●	●	●	●	●	
Power off	Sleep	Off	Off	Off	Off	Off	Off	All Off
Standby	Normal	Flash1	Off	According to the power capacity				Standby status
	Alarm	Flash1	Flash1					
Charging	Normal	On	Off	According to the power capacity				
	Over-current Alm	On	Flash2	According to the power capacity				Max.LED flash2
	Over-volt protection	Flash1	Off	Off	Off	Off	Off	
	Over-temperature/over-current protection	Flash1	Off	Off	Off	Off	Off	
Discharging	Normal	Flash3	Off	According to the power capacity				According to the power capacity
	Alarm	Flash3	Flash3					
	Over-temperature /over-current/short circuit protection	Off	On	Off	Off	Off	Off	Stop discharging, forced
	Under-vol protection	Off	Off	Off	Off	Off	Off	Stop discharging

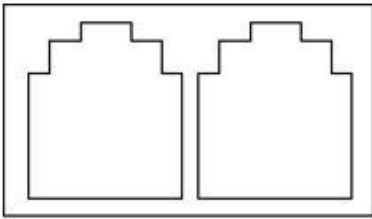

RS485 CAN

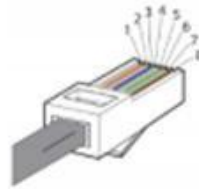

Pin Definition

CAN		RS485	
Pin	Define	Pin	Define
1,2,3,6,8	/	1,8	485- B
4	CAN- L	2,7	485-A
5	CAN-H	3,6	GND
7	CAN-GND	4,5	NC

5. Parallel Communication Cautions

For safe operation and compliance, it is necessary to check whether the appearance of each battery pack is damaged before paralleling. If there is no such situation, press the start button of the battery , visually check whether the LED indicator is normal, and then use the multi-meter measures the voltage value of each battery in turn. When the battery voltage difference exceeds 0.5 V,

it cannot be directly connected in parallel. The battery pack need to be charged and discharged separately so that the voltage difference is within 0.5 V, and then can parallel using.

When connecting in parallel, each battery must be turned off and used the parallel cable provide by us to ensure that the positive terminal(+) on the battery pack is connected to the positive terminal(+), the negative terminal(-) is connected to the negative terminal(-) and tighten the bolts. When the connection is complete, turn on each battery in turn.



All wiring must be performed by professionals.

Parallel Communication

When multiple machines are connected in parallel, the RS485 interface is used as the parallel communication interface, and the CAN interface is used as the uplink communication interface. The terminal device can read the sum of the battery data of all parallel BATTERY through the CAN interface.

Dialing Address Election

Parallel DIP switch definition: For multi-machine communication when batteries are connected in parallel, the DIP switch is used to distinguish different pack addresses. The hardware address can be

set by the DIP switch on the board. Refer to the table below for the definition of the DIP switch.

DIP Switch Settings

When multiple energy storage batteries are used in parallel, different energy storage batteries can be distinguished by setting the address of the DIP switch on the battery. It is necessary to avoid setting the same address. Refer to the following table for the definition of the BMS DIP switch.

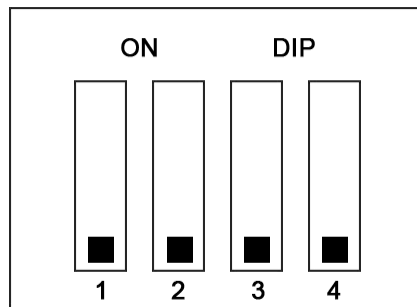

ADD	DIP switch position			
	#1	#2	#3	#4
0	OFF	OFF	OFF	OFF
1	ON	OFF	OFF	OFF
2	OFF	ON	OFF	OFF
3	ON	ON	OFF	OFF
4	OFF	OFF	ON	OFF
5	ON	OFF	ON	OFF
6	OFF	ON	ON	OFF
7	ON	ON	ON	OFF
8	OFF	OFF	OFF	ON
9	ON	OFF	OFF	ON
10	OFF	ON	OFF	ON
11	ON	ON	OFF	ON
12	OFF	OFF	ON	ON
13	ON	OFF	ON	ON
14	OFF	ON	ON	ON
15	ON	ON	ON	ON

Two Pieces In Parallel Diagram

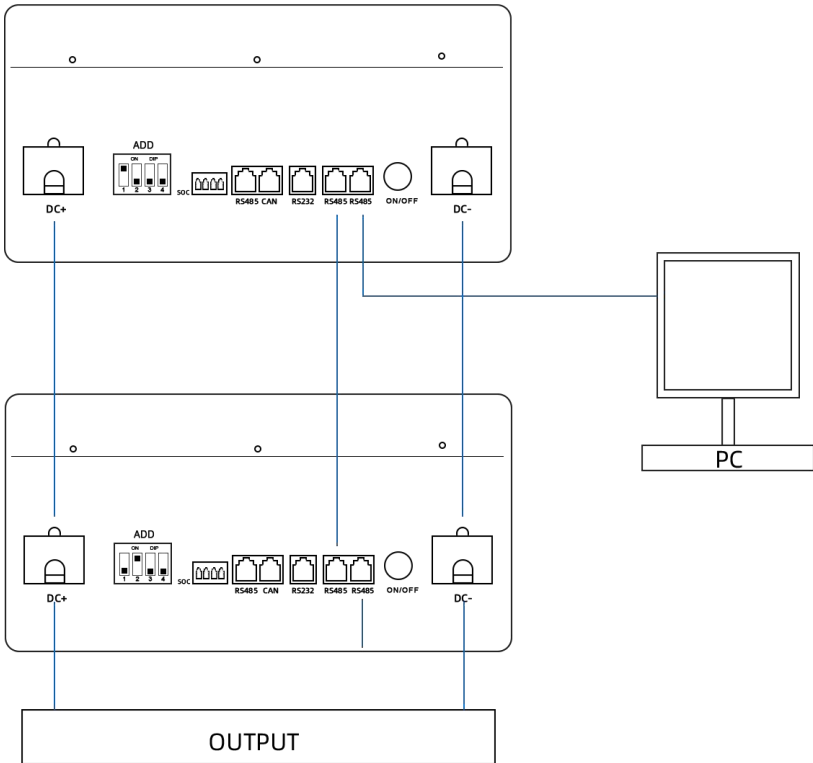

Three Pieces In Parallel Diagram

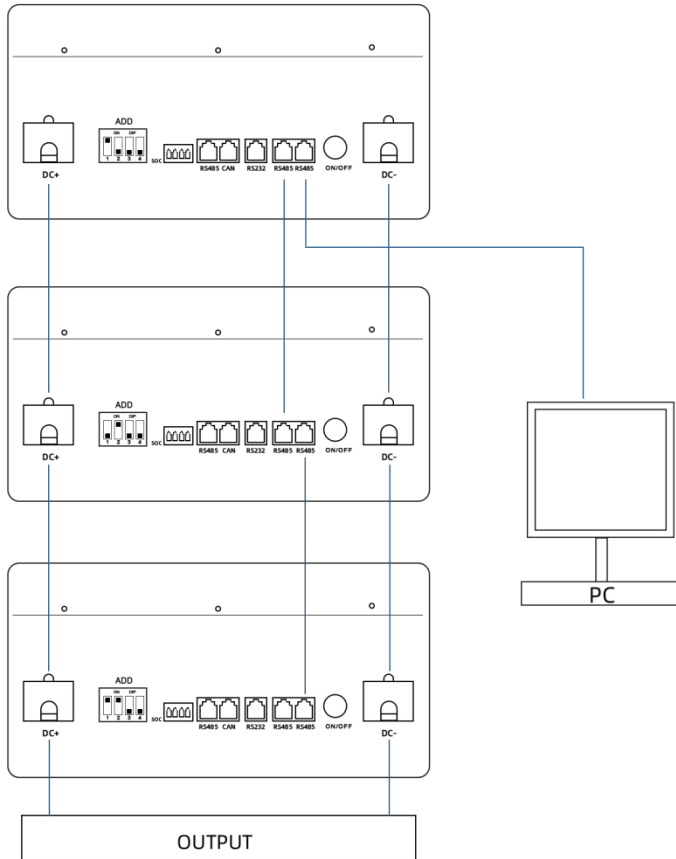

Four Pieces Parallel Diagram

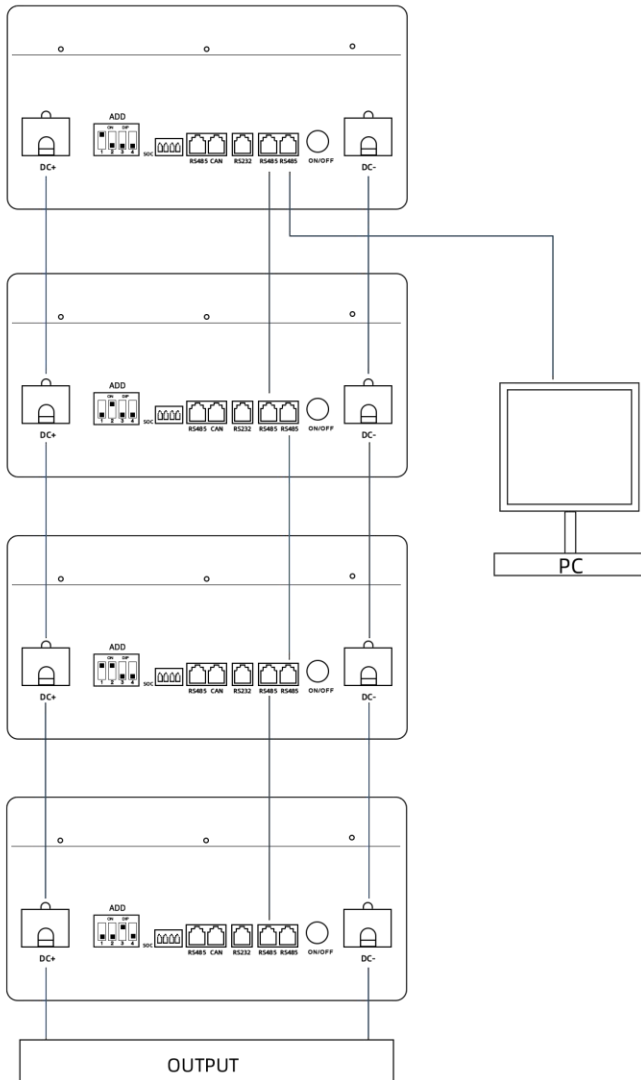

6. Connect To The Inverter

Schematic diagram of connection with inverter - simple connection

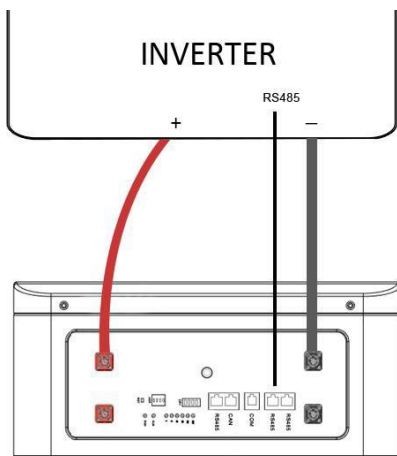

Schematic diagram of connection with inverter - recommended connection

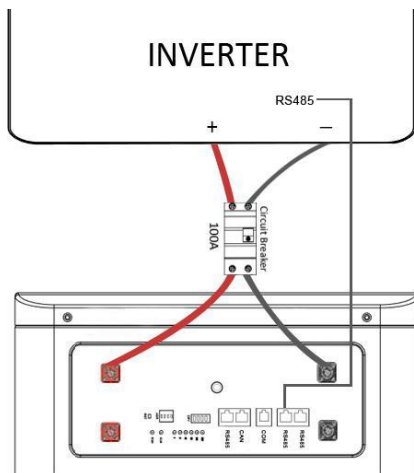

Power Cable Connection

The positive and negative poles of the product adopt a quick-plug interface, and the positive and negative poles can be distinguished by color (**RED** indicates the **positive pole**, **BLACK** indicates the **negative pole**), and the installer can directly connect the power cables to the positive and negative poles of the product when wearing protective gloves.

The power cable is connected with the product through a quick-plug interface, and connected with the inverter through a ring terminal.

Insert the ring terminal of the power cables into the battery connection port of the inverter, and ensure that the bolts are tightened with a torque of $2 \sim 3\text{N} \cdot \text{m}$. Make sure the polarity of the battery charge is properly connected, and the ring

terminal is tightened with the inverter end.

Power cables connection steps:

- ① Confirm that the inverter mains line is open and the PV line is open. Confirm that product is shut down.
- ② The ring terminal of the wiring cables is connected to the positive and negative poles of the DC terminal of the inverter.
- ③ The negative quick connector is connected to the negative port of Dawnice.
- ④ The positive quick connector is connected to the positive port of the Dawnice.



Warning: Before the installation of the power cables, the Dawnice and the inverter must be turned off.

Power cables disconnection steps:

- ① Make sure the mains line is open, and the PV line is open.
- ② Turn off the inverter switch.
- ③ Press the POWER button to turn off Dawnice.

- ④ Remove the quick plug connector of the negative power cables.
- ⑤ Remove the quick plug connector of the positive power cables.
- ⑥ Remove the ring terminal of the power cables.



Warning: Follow the steps strictly. And make sure the interface is in good contact.



Warning: The installation and disconnection of the wiring cables should be operated by qualified installers, and the user must not operate in private.



Warning: The power cables may transmit large currents. Please make sure that the children can not touch the power cable .

O n A n d O f f

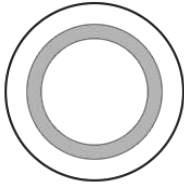

POWER

Startup Steps:

- ① Make sure the power cable is properly connected
- ② Press the POWER button

No.	Function	Remarks
1	Power on/ Start	When the BMS is in the dormant state, press the reset button once, the BMS will be activated, and the LED indicator will flash in turn, then it will enter the normal working state .
2	Power off/dormant	When the BMS is in the standby or discharging state, press this key for 3 seconds, the BMS will be dormant, the LED

		indicator will flash in turn, then it will enter the dormant state . The BMS has no power consumption after sleep .
--	--	---

③ Product boot

Remarks: Before the product is turned on, the internal relay of the battery will produce sound when it is switched on / off, which is normal.

Shutdown Steps:

① Make sure the power cable is disconnected

② Press the POWER button

③ Product shutdown



Remarks: Before the product is turned off, the internal relay of the battery will produce sound when it is switched on / off, which is normal.



Warning: The power-on and power-off actions of the POWER button are not emergency operations for security incidents. If there is a safety problem in the home energy storage system, please disconnect the leakage switch and isolation switch (in the distribution box) in time. (Confirmation required).



Ensure that the maximum continuous charge and

discharge power of DC terminal is less than 5000W during product operation.

7. Functional Description

- Standby state: After the BMS is correctly connected and powered on, and there is no protection state of over- voltage, under- voltage, over- current, short circuit, over- temperature, under- temperature, etc. , press the reset button to turn on the device, and the BMS is in standby state .

In the BMS standby state, the running light flashes, and the battery can be charged and discharged .

- Cell overcharge protection and recovery: When any section of the battery cell is higher than the set value of cell overcharge protection, the BMS enters the overcharge protection state, and the charging device cannot charge the battery .

After cell over-voltage protection, when the highest cell voltage drops below the cell overcharge recovery value and the SOC is lower than 96% , the overcharge protection state is released . It can also be discharged .

- Total voltage overcharge protection and recovery: When the battery voltage is higher than the total voltage overcharge protection setting value, the BMS enters the overcharge protection state, and the charging device cannot charge the battery . When the total voltage drops below the total overcharge recovery value and the

SOC is lower than 96% , the overcharge protection state is released . It can also be discharged .

- Single over-discharge protection and recovery: When any section of the battery cell is lower than the set value of the single over-discharge protection, the BMS enters the over-discharge protection state, and the load cannot discharge the battery . BMS shuts down after 1 minute of communication .

After over-discharge protection occurs , charging the battery pack can release the over-discharge protection state . Or press the reset button once, and the BMS will turn on and re-check whether the battery pack voltage reaches the restored value .

- Total voltage over-discharge protection and recovery: When the battery voltage is lower than the total voltage over-discharge protection setting value, the BMS enters the over-discharge protection state, and the load cannot discharge the battery. BMS shuts down after 1 minute of communication.

After over-discharge protection occurs , charging the battery pack can release the over-discharge protection state . Or press the reset button once, and the BMS will turn on and re-check whether the battery pack voltage reaches the restored value .

- Charge over-current protection and recovery: When there is no charge current limit function, the charge

over-current protection can be triggered .

When the charging current exceeds the charging over-current protection setting value, and the delay time is reached . The BMS enters the charging over-current protection, and the charging device cannot charge the battery .

After charging over-current protection occurs, the BMS will automatically delay recovery and re-detect the external charger current. Discharge can also release the charge over-current protection .

- Discharge over-current protection and recovery: When the discharge current exceeds the discharge over-current protection setting value, and the delay time is reached . The BMS enters the discharge over-current protection, and the load cannot charge the battery .

After discharge over-current protection occurs, the BMS will automatically delay recovery and re-detect the external load current. Charging can also release the discharge over-current protection .

The discharge over-current protection has two levels of protection, which can restore the transient over-current protection as well as the discharge over-current protection . The transient over-current protection will be locked when the condition is reached, and it must be turned off and turned on or the charging is released .

- Temperature protection and recovery: BMS has 6 temperature detection ports, which implement protection measures by monitoring temperature

changes .

- Charging and discharging high temperature protection and recovery: When charging and discharging, when any of the 4 batteries NTC is higher than the high temperature protection setting value, the BMS enters the high temperature protection . The BMS stops charging or discharging .

When the cell temperature is lower than the high temperature recovery value, the BMS resumes charging or discharging.

- Charging and discharging low-temperature protection and recovery: When charging and discharging, when the NTC of 4 batteries is below the low-temperature protection setting value, the BMS enters the low-temperature protection . The BMS stops charging or discharging .

When the cell temperature is higher than the low temperature recovery value, the BMS resumes charging or discharging .

- Environmental temperature alarm , power temperature protection: When NTC detects that the ambient temperature is higher than the set value of ambient high temperature, the BMS generates an alarm . BMS will not stop charging and discharging .

When NTC detects that the power temperature is higher than the power protection setting value, the BMS enters the power high temperature protection. Stop charging

and discharging .

- Equalization function: The BMS has standby and charge equalization functions. The BMS system uses an energy-consuming equalization circuit, and the equalization opening voltage is adjustable by software . Any section of the equalization opening condition is higher than the equalization opening voltage and the pressure difference meets the conditions .

The equalization stops when charging is stopped or the cell voltage difference is less than the set value.

Battery specifications

Model	PS- GC5KWH	PS- GC10KWH	PS- GC15KWH
Nominal Volt (V)	51.2V		
Nominal Capacity (AH)	100	200	300
Working Volt Range	44-58.4 V		
Recommend Charging Volt (V)	58		
Recommend Discharging Cutoff volt (V)	45		
Standard Charging Current (A)	50	100	

Max . Constant Charging Current(A)	100	200	
Standard Discharging Current (A)	50	100	
Max . Discharging Current (A)	100	200	
Temperature (°C)	- 1 0 °C ~ 6 0 °C (Recommend 1 0 °C ~ 3 5 °C)		
Allowable Humidity Range	0 ~ 8 5 % RH		
Storage Temperature (°C)	- 2 0 °C ~ 6 5 °C (Recommend 1 0 °C ~ 3 5 °C)		
Protection	IP21		
Cooling Method	Natural Air Cooling		
Maximum Dimension (W* D* H) for Power Wall	450*400*220	673*550*190	1071*409*264
Net Weight(KG)	98	108	130

8. Performance Test

Nominal Capacity

The battery pack is placed in 25 °C environmental chamber, 0.2C constant current and constant voltage to 54.65V, 0.05C cut-off, put it aside for 60 minutes; 1C discharge to 37.5V.

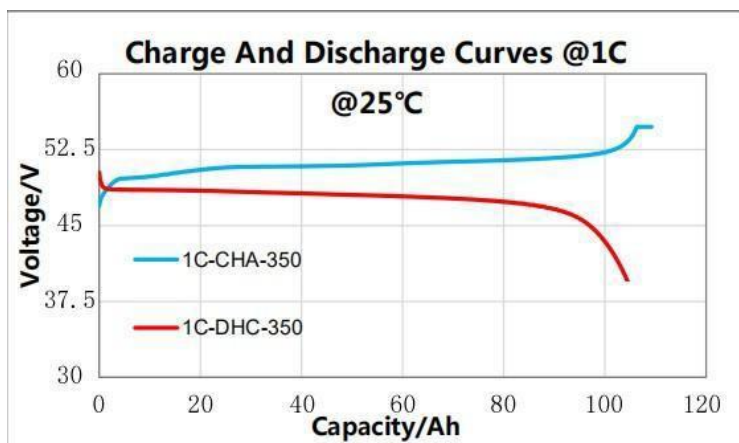
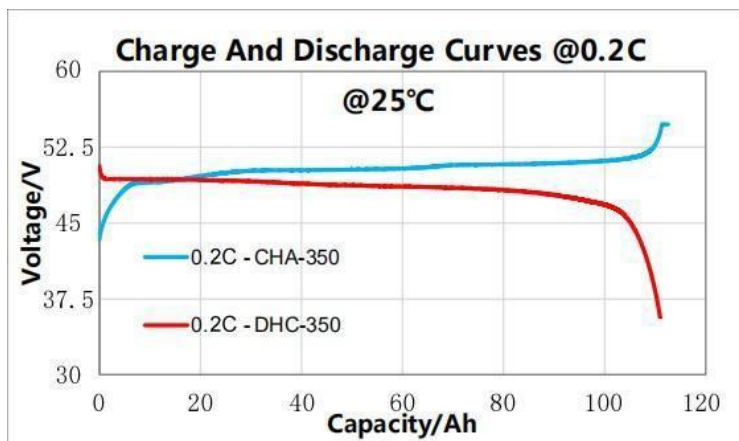

Rate Charging

The battery pack are charge data constant current of 0.1C,0.2C,0.3C,0.5C, and 1C to 54.75V in an environment of 25 °C . Stop charging after the constant voltage reaches 0.05C, and record the charging test data under different magnifications.

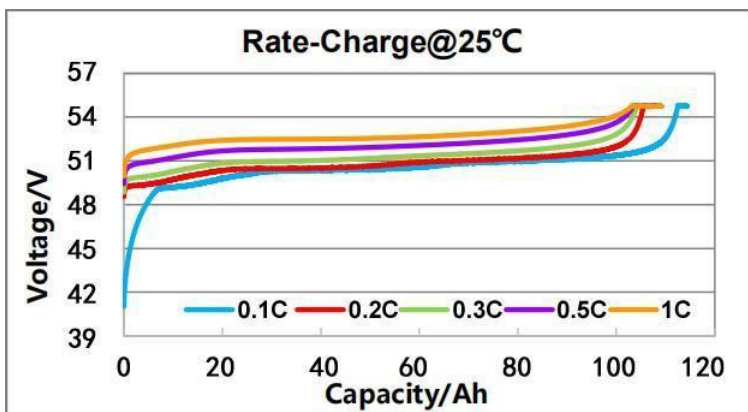
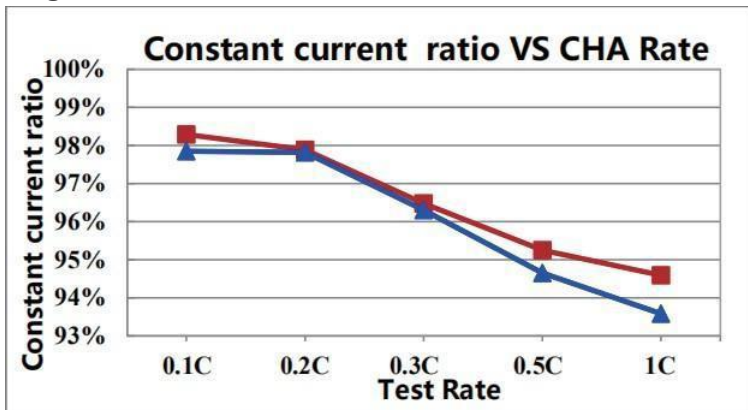

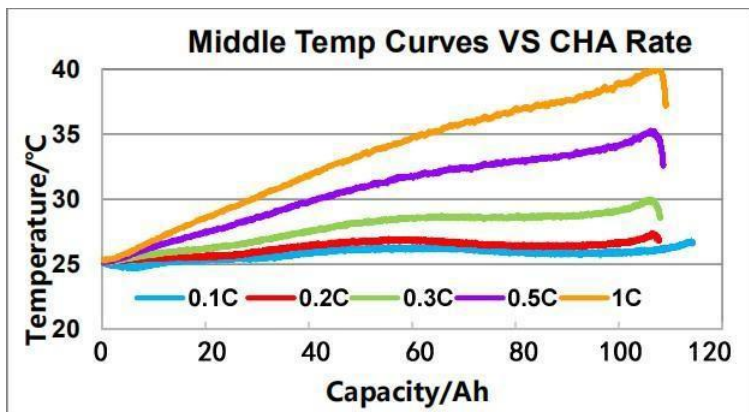

Rate Discharge

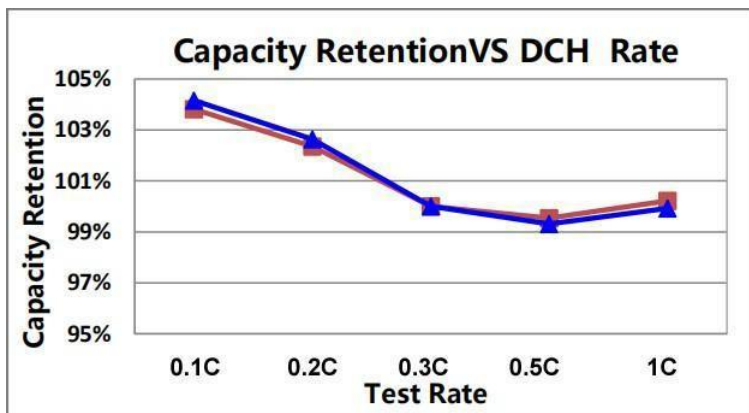

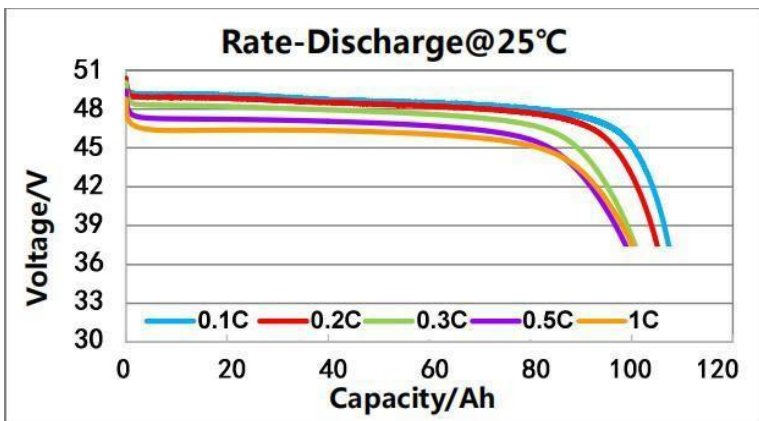
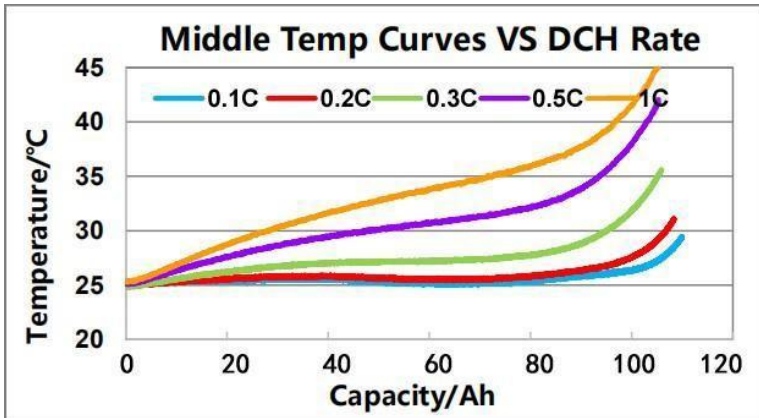

Storage performance-place at room temperature

In a normal temperature environment, 100% SOC storage for 28 days , test capacity retention and recovery rate (Test for 5 groups batteries)

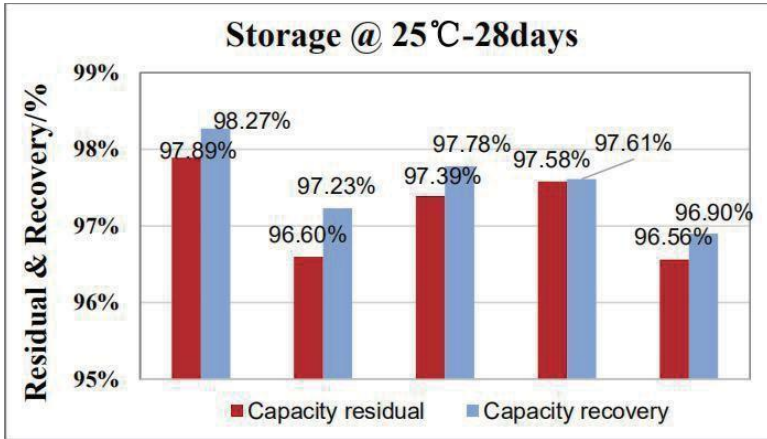

Storage performance-place at high temperature

55 °C , 100% SOC storage 4*728 days, test capacity retention and recovery
 Rate (Test average value for 5 groups batteries)

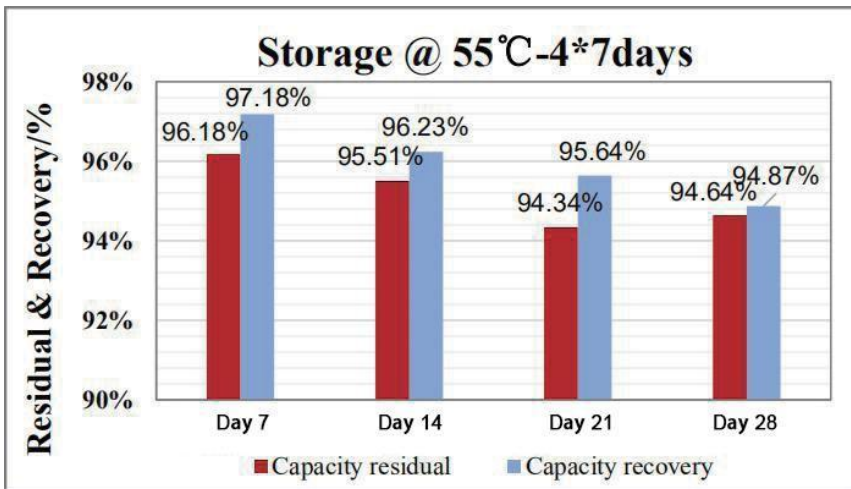

Cycle Performance

Testing Method:

25 °C , 0.2C constant current charge to 53.25V, constant voltage to 0.05C cut-off;

After 30 minutes of storage , 0.2C discharge Power to 42V, cycle to 80% SOC cut-off.

25 °C , 1C constant current charge to 53.25V, constant voltage to 0.05C cut-off;

After 30 minutes of storage, 1C discharge to 42V , cycle to 80% SOC cut-off.

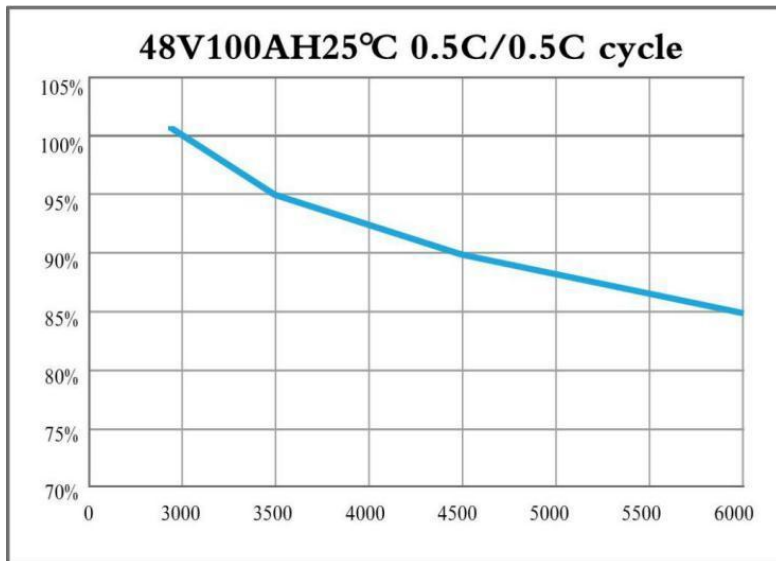

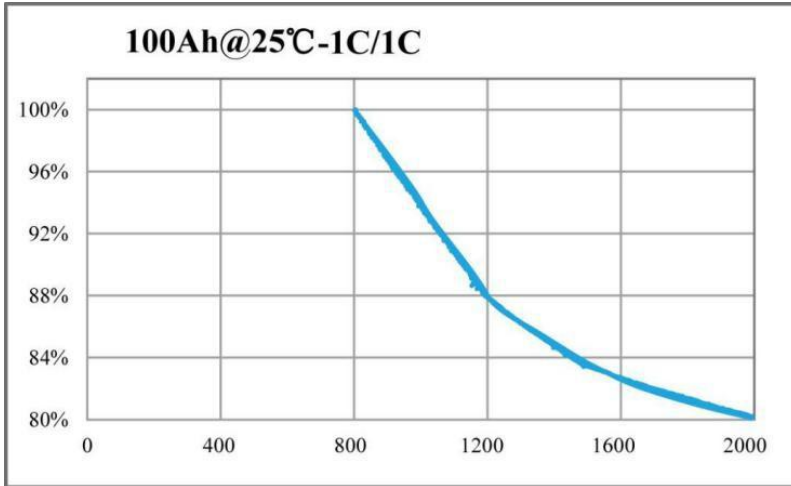

Trouble Shooting

If the system is not working properly, please perform the following steps:



Warning: product and inverter cannot be repaired by users, and must be repaired by certified installers.



Warning: If the product failure causes downtime and cannot be resolved in time, please report to product or product authorized service partner in time. If not reported to product or product authorized service

partner within 2 weeks after the failure, the warranty is invalid.

- If you cannot communicate with the inverter through the application, make sure that the Internet connection is normal.

- If neither the inverter nor the power switch responds:
 1. Turn off the inverter
 2. Cut off all input and output circuit breakers in the distribution box
 3. Press the POWER button to turn off product
 4. Wait at least one minute
 5. Press the POWER button to turn on the product
 6. Close the inverter switch and all input and output circuit breakers

Note: If an event (such as a thunderstorm) causes the system to become unresponsive. Do the following:

1. Turn off the inverter.
2. Open all input and output circuit breakers in the distribution box .
3. Make sure there is no electrical connection with product.
4. Press POWER button to close product.
5. Contact product support or product authorized dealer for help.

Technical Support

When contacting product, please provide the following information:

- Name of owner.
- Your effective way (phone, mobile phone or email) can let product contact .
- product serial number
- Brief description of the problem .

9. How To Deal With An Emergency

If your health or safety is threatened, please always start with the following two steps before dealing with the following other suggestions:

1. Contact the fire department or other emergency team immediately.
2. Inform all people who may be affected to ensure that they can evacuate the area.



WARNING: The actions suggested below can

only be Performed under safe conditions.

In Case Of :

- Turn off the inverter
- Press POWER button to turn off product
- Cut off all input and output circuit breakers in the distribution box
- Acceptable fire extinguisher types include: water, CO2, and ABC fire extinguishers

Avoid using type D (flammable metal) fire extinguishers .

In Case Of :

- If any part of the battery and inverter or wires are submerged in water, please keep away from water.
- Turn off the inverter
- Press POWER button to turn off product.
- Cut off all input and output circuit breakers in the distribution box .
- Make sure there is no electrical connection with product.
- If possible, protect the system by finding and stopping the water source and pumping the water away.
- Contact product technical support or product authorized dealers for help in time .

If there is odor or :

- Turn off the inverter.

- Press POWER button to turn off product.
- Cut off all input and output circuit breakers in the distribution box .
- Make sure there is no electrical connection with product. •
Ventilate the room and contact product technical support or product authorized dealers for help in time .

If product makes abnormal :

- Turn off the inverter.
- Press POWER button to turn off product.
- Cut off all input and output circuit breakers in the distribution box .
- Make sure there is no electrical connection with product.
- Contact product technical support or product authorized dealers for help in time .

10. When The Product Is Turn Off And Not In Use

product is a lithium-ion battery product and should not be stored for a long time.

Regardless of the reasons why the product is shut down and not used, please observe the product storage requirements in the following table.

Storage Temperature	Short-term storage of less than 1 month	-10°C ~ + 45°C
	Long-term storage of no more than 3 months	0°C ~ + 45°C



Do a full charge and discharge of the battery before the storage of the product expires, and the final charge SOC remains at about 50%.

1. System Message

The serial number of the product is on the product label. If your system needs repair, please keep this information.

Warranty Policy

This Limited Warranty (here in after "Warranty") specified below is applicable to product energy storage batteries system (here in after "Products") provided by Yichun Pengshi Manufacture & Trade Co., Ltd. ("ps" or "Seller") to End-user (hereinafter "Buyer") through ps or Authorized Reseller.

1. Purpose

The primary purpose of this Warranty is to clearly define the matters related to warranty policy of Products.

2. Warranty Condition

product warrants that, under normal use, the Product will be free from defects in material and workmanship in accordance with its applicable technical specifications.

2-1. Warranty Period

The products are provided with 3-year free Warranty. Since the installation date.

Note: When warranty is required, the buyer must provide with the installation date. If the buyer is unable to submit any proof of installation date, product will calculate the product Warranty period from the date of manufacture (date written on the product label).

Note: Outside the warranty period, product provides paid maintenance for the product.

product provides two methods of Warranty if the product 's operation does not meet the technical specifications during the free Warranty period: (I) Repair the nonconforming or defective products; or (II) provide the buyer with replacement parts. product shall be responsible for all reasonable repair or replacement costs associated with such non-conforming or defective products; however, the buyer shall bear the cost of removing the defective products and re-installing the repaired or replacement products.

2-2. Limitation of Warranty Scope

Product's liability under this Warranty shall be limited to replacement, repair, refund and compensation. Replaced or repaired Products shall be warranted for the remainder of the original Term of Warranty. In any event, the replacement shall not justify the automatic renewal or extending of the term of Warranty.

2-3. Exclusion of Warranty

Damage to the Products resulting from any of following activities is NOT covered by this Limited Warranty:

- The warranty period has expired.
- Improper transportation, storage, installation or wiring of the product.
- Modification, alteration, disassembly, repair works or replacements by someone other than personnel certified by product.
- Noncompliance with product's official installation, user guide or maintenance instructions.
- External influences, such as power failure surge, lightning, flood , fire, accidental damage or other events beyond products control.
- Use of non-specified and/or incompatible components like batteries, inverters, rectifiers or PCS.
- Any damage to the product caused by goods/other products (including any part) incorporated, installed or used together with the products.
- No report to Pengshi or Pengshi authorized service partners within 2 weeks after product failure.
- Product defects due to the updating of national or regional laws and regulations.
- When the product is sold to the end user, the defects cannot

be overcome under the technical conditions.

- The user fails to provide the correct product serial number or the product serial number cannot be decoded or modified without product's permission.
- When the product is turned off, it does not meet the storage requirements.

2-4. Warranty Service

The buyer shall contact the installer directly to avoid additional problems with the product.

Note: in shutdown mode, the product cannot protect itself from self-discharge.

3. Out of Warranty Policy

Products damage which is not caused by seller, product shall provide charged service, including all the expenses of such as material cost, labor cost, warehouse cost, transportation cost, customs duties, analysis cost, management overheads, disposal expense (If necessary) and so on.

4. About Service Products/Parts

Service products/parts are able to be used as new or refurbished condition which performance is equal to or higher than defective Products and guaranteed by product.

In the event the Products are not available in the market

anymore, product, at its option, may replace it with different kind of product with equivalent functions and performances.

5. Product Recycling Service

Customers are provided with product recycling services after the end of product life cycle by product. The judgment condition at the end of the life cycle is that the existing maximum capacity of the product is less than or equal to 60% of the nominal capacity of the product.

6. Claim Payment Policy

Returns of any products will not be accepted unless product authorizes them in writing in advance. The written authorization shall include the product model name, defect and/or fault description, serial number on the product label on the back of the product and the installation date.

7. Applicable Law

The Warranty is subject to the law of the region sold. Products come with guarantees that cannot be excluded under the

local Law. The Buyer is entitled to a replacement or refund for a major failure and compensation for any other reasonably foreseeable loss or damage. The Buyer is also entitled to have the goods repaired or replaced if the Products fail to be of acceptable quality and the failure does not amount to a major failure. The benefits to the consumer given by the warranty are in addition to any other rights and remedies of the consumer under a law in relation to the goods or services to which the warranty relates. This Warranty only applies to the Buyer who have purchased the Products for their own use.